

ENERGY RELATIONS IN TRANSIENT CLOSED-CONDUIT FLOW

By Bryan W. Karney¹

ABSTRACT: When the rate of flow in a closed conduit is changed, large-scale conversions of mechanical energy often occur, particularly if the pipeline is carrying water or some other slightly compressible liquid. Mathematical expressions describing these transient energy transformations are motivated from first principles and derived by mathematical manipulation of the governing continuity and momentum equations. The resulting expression accounts for the kinetic energy of the fluid, the internal energy associated with fluid compressibility and pipeline elasticity effects, the energy dissipated by friction, and the work done at the ends of the conduit. The energy approach provides an integrated view of transient conditions in the pipeline and is thus a simple, efficient, and logically consistent way of comparing the transient response of different systems and solution techniques. In particular, compressibility effects are shown to be negligible when the ratio of the change in internal energy to the change in kinetic energy is much less than one. This rule helps to distinguish the "rigid water column" model of unsteady flow from the more complex water-hammer theory.

INTRODUCTION

Analyzing and interpreting unsteady-flow phenomena in a pipeline is not easy. The governing partial differential equations can only be solved numerically, the behavior of hydraulic devices is complex, and pipeline systems are subjected to a wide variety of operating conditions and requirements. The most basic question of all—that of deciding whether or not conditions warrant transient analysis—is difficult to answer in general. Even when simulation is required, the detailed output of a transient-analysis computer program, with its seemingly endless sequence of head, velocity, and other values, may be somewhat bewildering. Although graphical summaries make it easier to understand the transient behavior of a particular system, generalizing or extrapolating this knowledge from one system or application to another is often difficult.

This paper develops an alternative interpretation of transient conditions in a pipeline. The new approach is built upon the traditional partial differential equations, but simplifies the presentation of transient information. In addition, the difficulty of visualizing the complex transmission and reflection of transient pressure waves is largely eliminated. Central to the new approach is an integrated "energy expression" that summarizes the transient response of the entire pipeline. Naturally, such a summary cannot provide a complete and detailed description of transient conditions at all locations within a pipeline. However, the energy expressions supply considerable physical insight and are a natural and direct way of understanding and comparing the performance of different systems. The energy expressions can easily be added to existing numerical models in order to complement and enhance traditional transient analysis.

¹Asst. Prof., Dept. of Civ. Engrg., Univ. of Toronto, Toronto, M5S 1A4, Canada.

Note. Discussion open until March 1, 1991. To extend the closing date one month, a written request must be filed with the ASCE Manager of Journals. The manuscript for this paper was submitted for review and possible publication on July 12, 1989. This paper is part of the *Journal of Hydraulic Engineering*, Vol. 116, No. 10, October, 1990. ©ASCE, ISSN 0733-9429/90/0010-1180/\$1.00 + \$.15 per page. Paper No. 25135.

Importance of Energy Relations

Energy concepts are at the heart of our understanding of the physical world. Whether one is evaluating how a system changes with time, quantifying a system's energy requirements, or simply determining what changes in a system are physically possible, energy concepts play a central role. This remarkable versatility arises from two principal sources: the number and diversity of the expressions into which energy enters and the fact that energy is conserved. For both these reasons, energy concepts are frequently useful when modeling the behavior of physical, chemical, and biological systems.

To illustrate the magnitude of the energy transformations in a closed conduit, consider a pipeline with a length $L = 1,000$ m and a cross-sectional area $A = 1$ m² carrying water with an initial velocity $V_0 = 2$ m/s. Since water has a density (ρ) of approximately 1,000 kg/m³, this pipeline contains 1,000 m³ of water having a mass of 10^6 kg, a momentum of $2(10^6)$ kg · m/s, and a kinetic energy T of $2(10^6)J$. If the fluid velocity at a point in the pipe were to be changed, say by suddenly closing a downstream valve, the kinetic energy of the pipeline would be eliminated in about 1 s. Thus, the rate of the energy transformation in this conduit would be about 2 MW. Such high rates of energy conversion are common whenever flow conditions change rapidly.

In the past, many authors have considered certain aspects of the energy transformations that occur under transient-state conditions. The role of frictional dissipation has been given particular attention, with the work of Gray (1953), Pearsall (1966), and Zielke (1968) being representative. The influence of free air in the calculation of dissipation rates has also been extensively studied (Tullis et al. 1976; Martin et al. 1976; Wylie 1980). In a more recent paper, Jelev (1989) develops an energy approach that allows for "structural friction"—i.e., energy losses as a result of stress-strain conditions in the fluid and conduit walls. Jelev develops his energy relations from first principles with the intent of modifying the traditional approach of accounting for viscous losses only.

The focus of this past work was to predict the long-term dissipation of mechanical energy under transient conditions. Understanding the short-term transformation of velocity into head and back again was accomplished by numerically solving (usually by the method of characteristics) the momentum and continuity equations. The present paper develops and extends the energy approach in order to describe how the pipeline as a whole responds to all conditions of flow, including its short- and long-term behavior.

This paper is organized as follows. First, an expression for the elastic energy in a pipeline related to the first law of thermodynamics is given. This first-principles approach provides physical insight into the mechanism of energy storage and its relation to simpler fluid (mass) storage concepts. Next, the same expression for elastic energy is obtained by mathematical manipulation of the usual continuity and momentum equations. This second approach, although less direct, has a number of virtues: (1) It demonstrates the consistency between the momentum and continuity expressions and the mechanical-energy expression; (2) it provides a quantitative expression for the rate of energy dissipation due to fluid friction in the conduit; and (3) it clarifies the role of work at the up- and downstream ends of the conduit in a

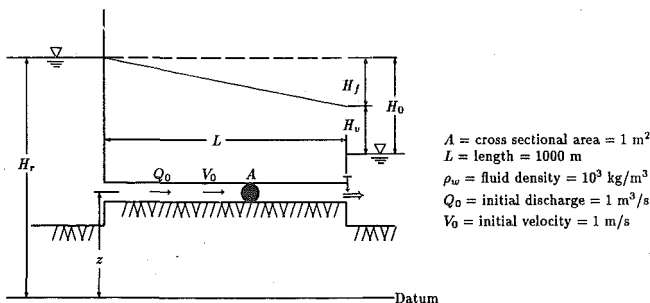

FIG. 1. Two Constant-Head Reservoirs Joined by Series Pipeline with Downstream Valve

way that allows generalization to more complex pipe systems. Following the derivations, it is shown that the energy expression provides a natural interpretation of the transient conditions within a pipeline. Most significantly, the classical distinction between “rigid-water-column theory” (in which the effects of water and pipeline elasticity are ignored) and “water hammer” analysis (in which elasticity effects are included) is resolved as a limiting case of the energy equation. A number of examples illustrate how the energy method can be applied to unsteady flow in closed conduits.

Internal Energy Expression

Transient conditions occur in closed conduits as a result of the control actions of valves, pumps, and other devices. In fact, unsteady flows arise as an inevitable consequence of any local flow adjustment that disturbs the usual steady-state balance between incoming and outgoing fluid, thus causing fluid to be stored within a conduit. However, because water and other liquids are only slightly compressible, a small flow imbalance can produce large pressure changes and thereby allow a considerable quantity of energy to be stored. The purpose of this section is to relate fluid and energy storage to the corresponding change in head in a pipeline.

To illustrate the relationship between fluid storage and head changes, consider Fig. 1, which depicts a horizontal pipe carrying fluid at an initial velocity V_0 . Suppose, for simplicity, that the valve at the downstream end of the pipe is suddenly closed and assume also that head losses due to friction (H_f) are negligible. The resulting head rise (ΔH) can then be accurately estimated by the Joukowsky relation

$$\Delta H = -\frac{a}{g} \Delta V \dots \dots \dots (1)$$

in which $\Delta V =$ change in velocity at the valve; $a =$ wave speed; and $g =$ acceleration due to gravity. During the time that the pressure wave is travelling up the pipe (L/a), water continues to enter the conduit at the initial rate. The additional volume of fluid added to the line (the “volumetric imbalance”) is $\Delta V = V_0 LA/a$ or, rearranging, $V_0 = a\Delta V/LA$. If this expression is substituted into Eq. 1 along with $\Delta V = -V_0$, the following linear relation between volumetric imbalance and head change is obtained:

$$\Delta V = \frac{gLA}{a^2} \Delta H \dots\dots\dots (2)$$

By considering only small adjustments in the downstream-flow rate, or by considering a decreasing sequence of initial velocities, it can be shown that Eq. 2 must also hold for infinitesimal changes in both volume dV and head dH .

Note in the aforementioned example that at the instant the pressure wave has travelled the length of the pipe, the flow is reduced to zero everywhere while the pressure is increased by a uniform ΔH . Thus, if a second valve at the upstream end were closed at this instant, "static conditions" could be preserved indefinitely. Moreover, the same final state could be achieved by an entirely different mechanism—namely, by compressing the fluid in a pipe under static conditions, say by slowly moving a piston at one end of the pipe.

The concept of fluid storage links the static case, in which the pressure increase is caused by the motion of a piston, and the transient case, which occurs because of local flow changes at a point. If the two cases use the same linearly elastic (reversible) model of the fluid and the pipeline, and if the volumetric imbalance is the same in both systems, the head rise will also be the same. Thus, it would be impossible to distinguish these two systems on the basis of their final state alone. This implies that the elastic energy stored in a pipe under transient conditions is, under the right circumstances, equivalent to that stored by a slow, mechanical compression of the fluid in the pipe.

For a slow, frictionless compression of the fluid, the work (and hence the increase in elastic energy) is easily calculated as $\delta W = p dV$, in which p = increase in internal pressure caused by the compression with dV = volume of fluid displaced by the piston's motion. For a pipeline, it is often convenient to replace p with H (setting the datum at the static-head level and using the relation $p = \rho gH$) and then use Eq. 2 to relate dV to dH . Using this information results in $\delta W = g\rho H(gLA)dH/a^2$. If all the terms in this expression except H are considered to be constant, then the expression for work can be written

$$\delta W = d\left(\frac{\rho LA g^2 H^2}{2a^2}\right) \dots\dots\dots (3)$$

If Eq. 3 is compared with the definition of energy from the first law of thermodynamics, it can be seen that the term in the parentheses is an energy expression. This form of energy is hereafter referred to as the internal energy U .

The internal energy can easily be generalized for those applications in which the head H varies both over the length of the pipe and with time. If $H = H(x, t)$, then the pipe length L in Eq. 3 must be replaced by an infinitesimal length dx and H integrated to obtain the total internal energy $U(t)$ at any instant. For a pipe with constant properties, the result is

$$U(t) = \frac{\rho A g^2}{2a^2} \int H^2(x, t) dx \dots\dots\dots (4)$$

Sometimes it is more convenient to represent the internal energy as an in-

tensive variable by dividing Eq. 4 by the mass of fluid contained in the conduit (ρAL). The expression for internal energy in an elastic pipeline carrying a slightly compressible liquid differs significantly from the corresponding relation for internal energy in a gas [e.g., Courant and Friedrichs (1944), page 418].

The internal energy is related to any event that changes the head or the distribution of head within a conduit. Clearly, sudden changes in head, such as those caused by pressure waves under transient conditions, will have a dramatic influence on the internal energy. It is in this way that internal energy helps to evaluate the relative significance of compressibility effects in closed-conduit flows.

ENERGY EQUATIONS

Although the direct approach presented thus far provides a natural interpretation of the internal energy of a pipeline, it is incomplete and awkward. The primary difficulty is that it does not distinguish "thermal effects" from the more useful concept of mechanical-energy dissipation. Although losses can be accounted for using temperature-change and heat-transfer concepts, mechanical forms of energy are usually of primary interest (most empirical equations account for dissipation in this way). The mechanical energy expression now developed includes the effects of flow work and viscous dissipation, without considering thermal effects. In addition, the relative importance of the energy terms is guaranteed to be compatible with traditional analyses. Indeed, both the new energy expressions and conventional simulations are based on the same governing equations.

The equations of continuity (mass conservation) and momentum are derived in standard references (Chaudhry 1987; Wylie and Streeter 1983). If x = distance along the centerline of the conduit; t = time; and partial derivatives are represented by subscripts, these equations can be written

$$V_t + gH_x + \frac{fV|V|}{2D} = 0 \dots\dots\dots (5)$$

$$H_t + \frac{a^2}{g} V_x = 0 \dots\dots\dots (6)$$

in which $H = H(x, t)$ = piezometric head; $V = V(x, t)$ = fluid velocity; D = inside pipe diameter; f = Darcy-Weisbach friction factor; a = celerity of the shock wave; and g = acceleration due to gravity. To be compatible, x and V must be positive in the same direction. As in the usual convention, $V(0, t)$ represents the velocity at the upstream end of the conduit and $V(L, t)$ is the velocity at the downstream end.

These equations are developed by applying Newton's second law and the law of mass conservation to an elementary control volume. The following assumptions and approximations apply to Eqs. 5 and 6.

1. The flow is one dimensional and conduit properties are constant throughout a pipe.
2. The "convective" and slope terms in the governing equations (i.e., the terms VH_x , VV_x and $V \sin \alpha$) are negligible.

3. The friction force includes all viscous stresses and can be approximated by the Darcy-Weisbach formula for steady flow. In addition, it is assumed that the friction factor f is either constant or weakly dependent on Reynolds number.

4. Flow occurs under essentially isothermal conditions (i.e., there is a negligible change in flow properties due to temperature).

The first step in obtaining the energy equation is to convert the momentum equation into an expression for kinetic energy. This is accomplished by multiplying Eq. 5 by V and rewriting it

$$\frac{1}{2} (V^2)_t + gVH_x + \frac{f|V|^3}{2D} = 0 \dots\dots\dots (7)$$

Now, to obtain an expression for the entire pipe, multiply this expression by dx and integrate over a length of pipe with constant properties (for simplicity, the domain of integration is eliminated in the following expressions). If the order of integration and differentiation is interchanged, the result is

$$\frac{1}{2} \frac{d}{dt} \int V^2 dx + g \int VH_x dx + \frac{f}{2D} \int |V|^3 dx = 0 \dots\dots\dots (8)$$

The first and third terms are related to the rate of change of kinetic energy and the rate of viscous dissipation, respectively. The second term, however, cannot readily be identified in this form.

To evaluate the $\int VH_x dx$ term in Eq. 8, multiply Eq. 6 by Hdx and again integrate over a length of pipe with constant properties. The result is

$$\frac{1}{2} \frac{d}{dt} \int H^2 dx + \frac{a^2}{g} \int HV_x dx = 0 \dots\dots\dots (9)$$

The first term in this expression is directly related to the elastic (internal) energy in the pipeline and the second term is reminiscent of the "unknown" term in Eq. 8. To make this correspondence more complete, consider the following integration by parts:

$$\int VH_x dx = -\int V_x H dx + V(L,t)H(L,t) - V(0,t)H(0,t) \dots\dots\dots (10)$$

Using Eq. 9, the right-hand side of this expression can now be written

$$\int VH_x dx = \frac{g}{2a^2} \frac{d}{dt} \int H^2 dx + V(L,t)H(L,t) - V(0,t)H(0,t) \dots\dots\dots (11)$$

All the terms on the right-hand side of Eq. 11 have a physical interpretation: the first is related to the rate of change of internal energy and the final two terms, apart from a missing factor of ρA , give the rate work is done at the downstream and upstream ends of the pipe, respectively.

If Eq. 11 is substituted into Eq. 8 and the result multiplied by ρA , the final energy equation for a pipe with constant properties can be written

$$\frac{\rho A}{2} \left(\frac{g}{a}\right)^2 \frac{d}{dt} \int H^2 dx + \frac{\rho A}{2} \frac{d}{dt} \int V^2 dx + \frac{f\rho A}{2D} \int |V|^3 dx + \rho g A V(L,t)H(L,t) - \rho g A V(0,t)H(0,t) = 0 \dots\dots\dots (12)$$

Eq. 12 represents the culmination of a rather long set of manipulations. Yet the form of Eq. 12 comes as no surprise: each term in was anticipated on physical grounds.

For convenience, the energy equation can be written in more compact form as follows:

$$\frac{dU}{dt} + \frac{dT}{dt} + D' + W' = 0 \dots\dots\dots (13)$$

in which T = total kinetic energy; D' = rate of viscous dissipation; and W' = rate at which work is being done to force fluid into and out of the line. This simple equation allows the following natural classification of flow regimes:

1. If the flow is steady, then the rate of change of internal and kinetic energy is zero; there is equilibrium between flow work (W') and the rate of mechanical-energy dissipation (D').

2. Flows can be assumed "quasi-steady" when the work and dissipation terms dominate the two transient terms. In this case, flow conditions do not depart significantly from steady state, and a time-stepping steady solution can be used to adjust flow and head values incrementally.

3. More rapid-flow disturbances disrupt the usual balance between dissipation and work, causing either or both of the first two terms in Eq. 13 to be nonzero. If the kinetic energy term dominates the internal energy term, the flow is unsteady and essentially incompressible (rigid water column). In fact, inspection of Eq. 4 shows that as the wave speed a increases without bound, the internal energy becomes zero, thus reproducing the classical representation of a transient incompressible model in which disturbances travel instantaneously from one location to another.

4. If both the internal and kinetic energy terms in Eq. 13 are significant, the flow is unsteady and compressible, and must be solved with a full transient (water hammer) analysis.

The question of quantifying the boundaries between these various zones is considered in more detail later. As a practical aside, it should be noted that two terms in the energy expression (the work and internal energy terms) are influenced by the selection of the hydraulic gradeline datum. Since this is undesirable, the internal energy U is actually calculated as

$$U = \frac{\rho A}{2} \left(\frac{g}{a} \right)^2 \int (H - H_0)^2 dx \dots\dots\dots (14)$$

in which H_0 is usually taken as the initial steady state head. Although this adjustment is not strictly necessary, it removes the effect of an arbitrary datum and has the virtue of isolating departures from the equilibrium position. By this means, the interpretation of transient conditions is simplified in much the same way that models of spring oscillations are simplified by measuring displacements with respect to the spring's equilibrium position. As a result of this change, U is always zero for the initial steady-state condition.

ENERGY TRANSFORMATIONS IN SIMPLE PIPELINES

Eq. 13 provides a summary of the complete transient response of a pipeline. The focus in the energy approach is no longer the traditional one of

determining what is happening at a particular location in the pipeline. Rather, the central issue is this: to understand how and why the pipeline as a whole responds as it does to transient conditions. To be sure, the question of what happens at a point is important and cannot be entirely forgotten. However, in a system with rapidly propagating and interacting waves, the phenomena at a point cannot be understood in isolation. What happens at a particular location is better understood and interpreted once the response of the whole system is explained and summarized in a convenient fashion. This insight is what makes the energy approach powerful.

The energy approach is now used to describe the behavior of a number of pipelines. The applications are typical but no attempt is made to assemble an exhaustive or complete set of illustrations. Many more examples could be generated, since the integration required to evaluate the energy terms in Eq. 13 is simple and can easily be added to an existing water-hammer program. It should be noted that although the examples involve simple pipe systems (upstream reservoir with downstream valve) this is by no means a requirement; the interpretation of other transient conditions, such pump failure or resonance in a pipe subject to periodic forcing, can also be enhanced by the energy approach. Valve closures are illustrated because they are familiar and easy to understand.

At first, however, consider a simple system—so simple, in fact, that a numerical solution is not required. If the internal energy U and the kinetic energy T of a pipeline are summed, Eq. 13 states that the value of this sum can only change as work is done on the conduit or as energy is dissipated from it. In particular, the work term can be forced to zero by suddenly closing a downstream valve while maintaining constant-head reservoir upstream. If the rate of energy dissipation is negligible, Eq. 13 requires the rate of change of $(U + T)$ to be zero. That is, $U + T = \text{a constant}$. Thus, in this system there is a dynamic conversion of kinetic to internal energy and back again. For historical reasons, the transient produced in such a frictionless pipe with an instantaneously closing downstream valve is termed a Joukowsky response.

Example: Energy Relations for Valve Closure with Friction

Now consider a modest extension to the aforementioned example. Suppose that the valve at the downstream end of a pipeline, such as the one shown in Fig. 1, is closed quickly, but not instantaneously, as was assumed previously. Also assume that the head losses in the pipe due to friction are no longer negligible. With these minor complications, a computer program must be used to obtain an approximate solution to the continuity and momentum equations.

For this and several of the subsequent examples, the pipeline system is assumed to have the following properties: $L = 1,000$ m; $A = 1$ m²; $a = 1,000$ m/s; the friction factor $f = 0.050$; and a steady-state discharge in the line of 2 m/s when the downstream discharge valve is fully open. In addition, a time step of 1/16 second is used in the method of characteristics solution.

For this system, the expressions for U and T are computed by a transient-analysis program for a linear closure of the downstream valve in 2 seconds. The results of this analysis are shown in Fig. 2, which plots the internal

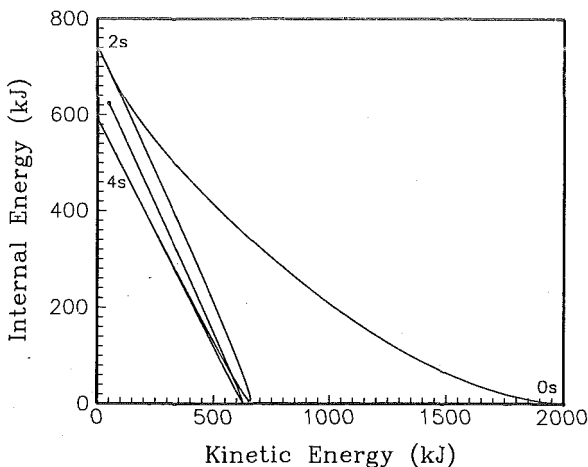

FIG. 2. Energy Transformations Occurring in Simple Pipeline with Friction and Rapidly Closing Valve

energy U on the vertical axis and the kinetic energy T on the horizontal axis. Each system state at a particular instant in time can be depicted as a point in the U - T plane; as the pipe responds to the flow disturbance generated by the closing valve, this point traces a path on the energy plane. It is the shape and character of this path that summarizes the evolution of the system under transient conditions.

The following points can be noted in Fig. 2.

In the Joukowsky case (i.e., if both the work and the frictional dissipation are zero), the state of the system traces out a sequence of overlapping straight lines between equal energy values on the T - and U -axes. If the rate of energy dissipation due to friction is included in the analysis, the paths are still approximately straight but decay slowly in a zigzag pattern toward the origin of the kinetic energy axis. This pattern is clearly seen in Fig. 2.

The time during which the valve closes appears as the curved path beginning at 2,000 kJ on the T -axis, ending near the 2 second label on the internal energy axis. In general, whenever a significant amount of work is done during transient conditions, the path of the system departs from the simple decay pattern discussed in the foregoing paragraph.

If the valve is instantly closed in this system, the full 2,000 kJ of kinetic energy is converted to elastic energy. Since the maximum amount of elastic energy is less than 800 kJ, more than 1,200 kJ of work is done during the 2 seconds the valve is closing. It is interesting that although the closure of the valve is so rapid that the maximum possible head rise occurs at the valve, there is still considerable benefit to the system as a whole as a result of the work done by the valve.

The ultimate decay to steady-state conditions occurs slowly in this system, even though frictional losses are quite large. Usually these losses are even smaller; the high value of f was chosen to make the frictional decay more visible.

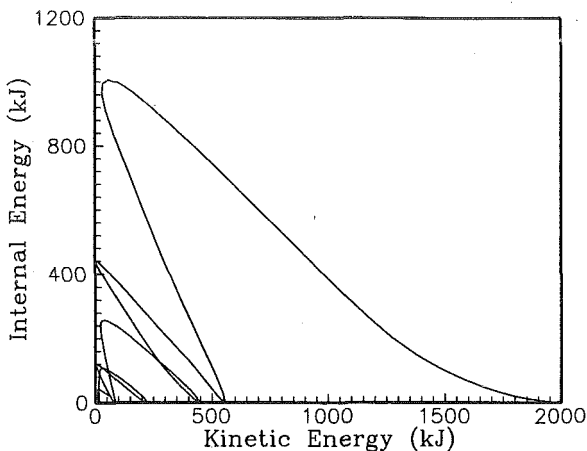

FIG. 3. Energy Transformations in Simple Pipeline with Valve Closed to Final Value of 10% of Its Initial Opening

Energy Relations for Other Valve Motions

The previous example considered the case of a control valve that rapidly changes from a fully open to a fully closed position. However, not all valve motions produce the same response. In fact, the nature of the transient response is quite sensitive to the details of the valve operation. To illustrate this point, several additional examples are presented. These represent: (1) The rapid closure of a valve to a partially closed position; (2) rapid opening of a valve (system startup); and (3) an example of an "optimum" closure, in which the motion of the valve is carefully controlled to produce an idealized response.

Partial Closure of Valve

In Fig. 3, the transient response of the same physical system is depicted for a different valve motion. As before, the valve is closed linearly from its fully open position, but now the duration of the valve motion is decreased to 1 second and the closure is curtailed at 10% of the initial opening. Although this may appear a relatively small change, a comparison of Figs. 2 and 3 reveals many differences.

The presence of the partially closed valve at the downstream end of the line allows the state of the pipeline to be changed by three mechanisms. As in the previous example, the frictional dissipation of energy still plays a role, as does the work during the time the valve is being closed. But now work can be done continuously at the partially closed valve after the closure is completed. This additional work term allows the state of the system to be changed more rapidly and diminishes the importance of the strain energy stored in the pipeline. Thus, although the valve motion is more rapid, Fig. 3 shows that the transient condition is only slightly more severe in this system (a larger value of internal energy is reached), while the transient condition is less prolonged (the state of the system rapidly converges to its new value).

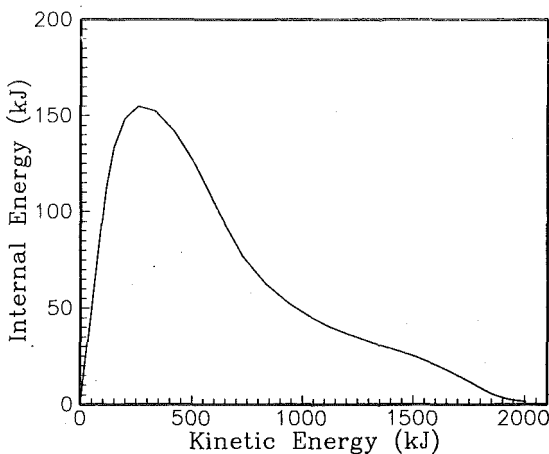

FIG. 4. Energy Transformations in Simple Pipeline during Valve Opening

Valve Opening

When a valve is suddenly opened, the kinetic energy in the pipeline rapidly increases. Ultimately, once a final steady-state condition is reached, the energy dissipated in this system is supplied by the work at the ends of the conduit; initially, however, the work terms are often insufficient to generate the required kinetic energy (this initial phase often generates the most severe transient conditions). As in the previous example, the work terms tend to produce a less-severe transient condition and a rapid convergence to the final steady state.

These observations are clearly illustrated in Fig. 4. In this example, the physical system is identical to that used previously except that the downstream valve starts closed and the initial flow is zero. As the valve opens, the kinetic energy builds up as work is done at the ends of the line and as energy is "released" from changes in internal energy. However, the ratio of the maximum change in internal energy to the change in kinetic energy is only about 0.08 (that is, $160/2,000$); this compares to a ratio of 0.4 for the same system when the valve is closed ($800/2,000$ from Fig. 2). It should be noted that the differences between these two systems arise exclusively from the work terms—the valve is operated in an identical fashion (except that the direction is reversed) and the role of viscous dissipation is negligible.

Optimum Valve Closure

The transient conditions initiated by valve operations can frequently be severe. For this reason, a number of synthetic closure arrangements have been developed to control both the magnitude and duration of transient conditions following valve closure. In these "valve stroking" procedures [e.g., Wylie and Streeter (1983)] the valve is operated so as to control the magnitude of the peak pressure in the line while ensuring that the final state of the system at the completion of the closure is steady. Inasmuch as these procedures limit or restrict the transient behavior of a pipeline, they are considered to be "optimal."

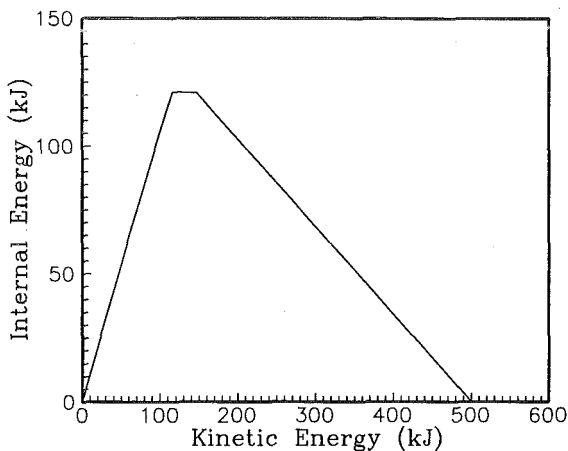

FIG. 5. Energy Transformations during "Optimum" Valve Closure

Fig. 5 illustrates the energy transformation that occurs during a stroked-valve closure in the previous system, with the valve completely closing in 2.125 s. The initial flow of $1.0 \text{ m}^3/\text{s}$ corresponds to a kinetic energy of 500 kJ. As can be seen on the plot, the kinetic energy decreases and the internal energy increases over the first part of the closure. After a peak value of the internal energy is briefly held, both the internal and kinetic energy decrease toward zero. At this point, the entire pipeline is brought into equilibrium at the reservoir elevation.

It turns out that one of the merits of the energy method is the ease with which different pipeline responses can be identified. The inverted V-shape associated with this example appears to be quite characteristic of optimum closures. Near-optimal closures, or control actions that coincidentally approximate an optimum closure, are easily recognized from their V-shaped energy "signatures."

IMPORTANCE OF COMPRESSIBILITY

The systems discussed so far are quite typical. Closed conduits frequently carry huge amounts of momentum and kinetic energy. Only when changes in flow rate take place very gradually, such that the mass and energy imbalances in the line are always small, is it possible to smoothly change the flow from one steady condition to another. In such applications it may be justified to neglect compressibility effects and use the rigid-water-column model mentioned earlier. However, rapid changes, whether caused by standard operating procedures or accidental events, can create large pressure pulses capable of bursting or damaging pipelines.

Yet one of the most difficult questions to answer in general is, How rapid is rapid? That is, how can the analyst know whether compressibility effects are important and what errors might be introduced by using the rigid-water-column model? As the following discussion shows, energy methods provides a general way of answering such questions.

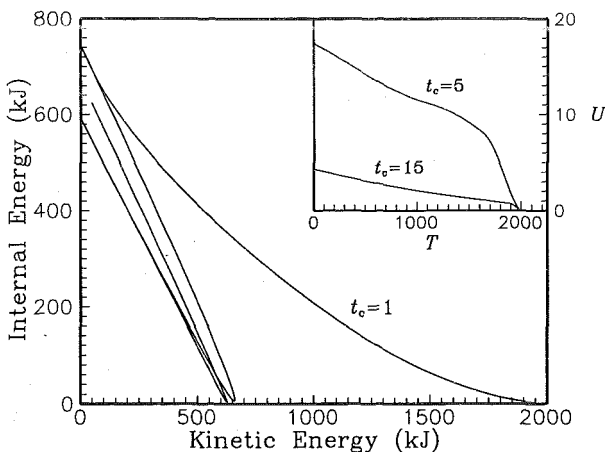

FIG. 6. Energy Transformations for Different Closure Durations (t_c = Nondimensional Closure Time)

In essence, when the equilibrium conditions in a conduit change, work must be done on the pipeline. However, if the hydraulic state changes more rapidly than can be accommodated through the work terms, energy storage—that is, the transformation of energy between the kinetic and internal forms—becomes progressively more important. Thus, the ratio of the total change in internal energy to the total change in kinetic energy provides a natural index of the importance of compressibility effects. Thus, if ϕ is the compressibility index then

$$\phi = \frac{|\Delta U|_{\max}}{|\Delta T|_{\max}} \dots \dots \dots (15)$$

In the limit as ΔU approaches zero, the compressibility index ϕ approaches zero. As has been shown, the original definition of U (Eq. 4) guarantees that this limit is achieved as the wave speed a approaches infinity. In effect, flow disturbances propagate instantaneously relative to the rate of change in the work and dissipation terms.

To illustrate this discussion, consider the full-size graph in Fig. 6, which shows the same system as Fig. 2. The 2 second valve closure in this example represents the time for a disturbance to propagate from one end of the conduit to the other and back again. Thus, the nondimensional time for the closure (t_c) is one wave travel time. The curves shown in the inset graph are for closure times of $t_c = 5$ (i.e., 10 s); and $t_c = 15$ (i.e., 30 s).

It can be seen in Fig. 6 that the compressibility index changes from a value of 0.4 (i.e., $\phi = 800/2,000$) for a closure in one wave travel time to a value of 0.002 when $t_c = 15$ (i.e., $\phi = 4/2,000$). For comparison, an intermediate value of closure ($t_c = 5$) is also shown. Clearly, the change in state in a pipeline with a longer-duration valve closure is almost totally accounted for by the work at the ends of the conduit. Very little energy is stored. By contrast, when the time of valve closure is small, most of the change in kinetic energy is temporarily stored as an increase in internal en-

ergy, as is indicated by the large value of the compressibility index.

Since all major changes of state are accounted for in the energy analysis, these conclusions are general. That is, whenever the value of ϕ is large (say greater than 0.1), compressibility effects are important; as the value of ϕ decreases (say to values less than 0.01), compressibility effects become less important and the rigid-water-column model becomes a better approximation of the transient response of the pipeline. Values of ϕ between about 0.01 and 0.1 indicate that compressibility is moderately important and can be neglected only with some loss of accuracy. Note that since the rigid-water-column model is by its nature an approximation, no absolute limits of ϕ values can be given. It is really a question of trading numerical accuracy for computational speed; the writer has found that limit of $\phi = 0.01$ represents a good working compromise for a wide range of systems and applications.

Although the compressibility index is influenced by anything that alters the dynamics of a system, the evaluation is always consistent with the physical nature of the flow disturbance. For example, if the initial discharge is increased by a factor of 10 to 20.0 m³/s, the initial kinetic energy and dissipation are increased 100 and 1,000 times, respectively. Despite these large changes, if the valve is still closed in 2 seconds, the ϕ -index only increases by 50% (from 0.4 to 0.6). This illustrates how stable the ϕ -index is with respect to both initial condition and friction loss and contrasts with its high sensitivity to valve closure time.

Adaptive Time Step Control

The power of the ϕ -index to characterize a pipeline's response has important implications for transient analysis. In most applications, the analyst does not make only one computer run; rather, many different initial states and device combinations may be investigated. For a given series of these numerical experiments, only one run may be required to determine the ϕ -index in a general way for the whole set. Suppose this is done and the index turns out to be less than 0.01. This would mean that the pipeline's behavior is insensitive to adjustments in the value of the wave speed and that the pipeline can be approximated by the rigid-water-column model. Thus, rather than using the more computationally demanding water-hammer approach, the analyst could switch to a rigid-water-column approach, with corresponding gains in computational efficiency.

Note also that as the compressibility index becomes smaller, the transient behavior of the conduit becomes progressively less sensitive to the value of the wave speed used in the analysis. Hence, if ϕ is small, the wave speed need not be known accurately, and practices such as adjusting the wave speed in the method of characteristics solution are fully justified in these cases. In fact, the time step in a transient model can sometimes be greatly increased (thereby cutting run times) by making large adjustments in wave speed values in applications in which the ϕ -index is very small. In this way a full transient model could be used to efficiently simulate not only rigid-water-column behavior, but quasi-steady states as well.

It should be emphasized that the conclusions based on the ϕ -index are independent of location and time in the pipeline. The energy terms used to define the value of ϕ relate to the entire pipeline and as such do not depend on where in the pipe or when in the simulation the term is evaluated. As a

result, the ϕ -index is ideally suited for the aforementioned kind of adaptive algorithm. That is, the index evaluates the influence of compressibility during a particular time step; if compressibility is important, the current time step can be decreased to improve accuracy. On the other hand, if compressibility effects are not important, the time step is increased (say by wave-speed adjustments) to obtain an equivalent degree of accuracy at less expense.

Comparison with Other Methods

To put the energy approach into historical perspective, it is worthwhile comparing it to other methods of assessing the importance of compressibility. Traditionally, the question, How rapid is rapid?, is answered by comparing the duration of valve motion to the wave travel time in the pipe system (t_c). Thus, for linear closures the typical criterion is that rapid closures (i.e., those requiring compressibility effects to be accounted for) take place in less than 5 wave travel times (i.e., $10L/as$), while longer closures can be modeled by assuming an incompressible fluid (Karney and Ruus 1985).

However, as Karney and Ruus show, the appropriate limiting value depends not only on the duration of valve closure, but also on the head loss due to friction and on various pipe parameters. (The "pipe constant" can be summarized by the nondimensional Allievi parameter, usually written as $aV_0/2gH_0$, in which the subscript 0 indicates the initial steady-state values.) Thus, to use timing criteria directly, requires a number of qualifiers for each limiting value—the analyst must specify for what system and kind of closure the limit applies. The energy approach is not limited in this way, for the ϕ -index applies to all systems regardless of exact form of the closure curve or value of friction in the system.

To be sure, there is a certain familiarity about the ϕ -index. If one designates the wave time scale of a simple system as L/a and designates the inertia time scale as VL/gH , then dimensionally, the ϕ -index is closely related to the time scale divided by the inertia time scale squared; i.e., $(gH/Va)^2$. The difficulty is how to select the various terms in this fraction. Note that in the traditional Allievi parameter—to which the timing ratio is obviously related—steady conditions are used, which are notoriously poor indicators of compressibility effects. Yet, if transient values are employed, what values of V and H best characterize a system's response? The energy method is insightful because it clarifies for any system both the significance of the ratio and how it should be computed (i.e., as the integral of squared values along a pipe).

CONCLUSIONS

The complexity of transient analysis makes it difficult to generalize the performance and behavior of pipeline systems. The designer must choose from a bewildering range of pipeline profiles, material types, and control devices; the operator must select a set of control rules and policies that guarantee safe and reliable performance; and the analyst must identify stable, accurate, and efficient models to predict the pipeline's behavior under a set of real or hypothetical conditions. To make headway with this kind of problem, what is needed is a way of visualizing, interpreting, or simplifying transient conditions that is both accurate and physically meaningful. Al-

though the complexity of the transient phenomena in pipelines means that no single graphical summary can completely describe transient conditions, the energy approach provides considerable insight into a pipeline's response and can be used to complement more traditional graphical approaches.

Even though parts of the derivation are somewhat difficult, the final energy expressions are easily calculated and interpreted. Unlike traditional methods, the energy approach focuses attention on the up- and downstream ends of the conduit. It turns out that the work done at the ends of the pipe largely determines the response of the conduit as a whole. What happens at the ends of a pipe is usually of greatest concern to pipeline owners and operators in any case, since it is here that the most expensive devices are often installed and that the most important flow-control operations must take place. Thus, by directing attention to a few key locations, and by lumping together the rest of the system in a physically significant fashion, the energy approach simplifies the interpretation of transient conditions in a pipeline.

As a result of these benefits, the energy relations provide a natural means of quantifying errors in the analysis that might arise because of differences in either the physical representation of the pipe system or the mathematical approximations used in modeling it. Most significantly, the energy relations allow the role of compressibility and energy storage under transient conditions to be quantified—as the compressibility index approaches zero, the rigid-water-column model becomes a better approximation of the transient behavior of the system. Such generalizations are a direct outcome of the simplicity and power of the energy methods of transient flow analysis.

APPENDIX I. REFERENCES

- Chaudhry, M. H. (1987). *Applied hydraulic transients*. Van Nostrand Reinhold Co., New York, N.Y.
- Courant, R., and Friedrichs, K. O. (1948). *Supersonic flow and shock waves*. Springer-Verlag, New York, N.Y.
- Gray, C. A. M. (1953). "The analysis of the dissipation of energy in water hammer." *Proc., ASCE*, 19, 1176–1194.
- Jelev, I. (1989). "The damping of flow and pressure oscillations in water hammer analysis." *J. Hydr. Res.*, 27(1), 91–114.
- Karney, B. W., and Ruus, E. (1985). "Charts for water hammer in pipelines resulting from valve closure from full opening only." *Canadian J. Civ. Engrg.*, 12(2), 241–264.
- Martin, C. S., Padmanabhan, M., and Wiggert, D. C. (1976). "Pressure wave propagation in two-phase bubbly air-water mixture." *Proc., 2nd Int. Conf. on Pressure Surges*, BHRA, Bedford, England, C1–16.
- Pearsall, I. S. (1966). "The velocity of water hammer waves." *Symp. on Surges in Pipelines, Proc., Inst. Mech. Engrg.*, 180(3E), 12–20.
- Tullis, J. P., Streeter, V. L., and Wylie, E. B. (1976). "Waterhammer analysis with air release." *Proc. 2nd Int. Conf. on Pressure Surges*, BHRA, Bedford, England, C35–47.
- Wylie, E. B. (1980). "Free-air in liquid transient flow." *Proc. 3rd Int. Conf. on Pressure Surges*, BHRA, Canterbury, England, 27–42.
- Wylie, E. B., and Streeter, V. L. (1983). *Fluid transients*. FEB Press, Ann Arbor, Mich.
- Zielke, W. (1968). "Frequency-dependent friction in transient pipe flow." *J. Basic Engrg.*, *Trans. ASME*, 90(D), 109–115.

APPENDIX II. NOTATION

The following symbols are used in this paper:

A	=	cross-sectional area of pipe;
a	=	wave celerity;
D	=	inner pipe diameter;
D'	=	rate of energy dissipation;
d	=	derivative;
E	=	energy (a property);
f	=	Darcy-Weisbach friction factor;
g	=	acceleration due to gravity;
H	=	piezometric head;
H_f	=	head loss due to friction;
L	=	length of pipeline;
p	=	fluid pressure;
Q	=	volumetric rate of flow;
T	=	total kinetic energy of pipeline;
t	=	time;
t_c	=	nondimensional valve closure time;
U	=	total internal energy of pipeline;
V	=	fluid velocity;
V_0	=	initial fluid velocity;
W	=	work done on control system;
W'	=	rate work is done on control system;
∇	=	volume of fluid in control volume;
x	=	distance along pipe;
α	=	pipeline slope;
γ	=	specific weight of fluid;
Δ	=	change or incremental change;
δW	=	incremental work interaction;
ϕ	=	compressibility index; and
ρ	=	mass density.